

FLUSH VALVE

47087-07

3156.015

INSTRUCTIONS**FOR INSTALLING NO 4 FLUSH VALVE
REPLACEMENT KIT FOR NO. 3 FLUSH VALVE IN
ONE—PIECE**

1. Remove No. 3 flush valve and trip lever.
2. Plug small holes in china by inserting seals (15) provided
3. Place Unit "A" in outlet of
4. Run the clamping lugs up against the underside of tank outlet and tighten the lug screws so that even pressure is applied to the sealing ring.
5. Attach Unit "A" to Unit "B".
6. Install the trip lever furnished with valve.
7. Connect the lift chain as shown and adjust at the trip lever end so that minimum slack remains.
8. Replace float rod with the one furnished with valve and adjust float rod for correct water level. Test closet to make sure that float ball arm does not interfere with action of flush valve.

IMPORTANT

THIS VALVE IS NOT A SUITABLE
REPLACEMENT IN ANY COMBINATION
IN WHICH OUTLET IS NOT IN CENTER OF TANK

FLUSH VALVE

47087-07/47086-07

3156.015



NO. 3 FLUSH VALVE

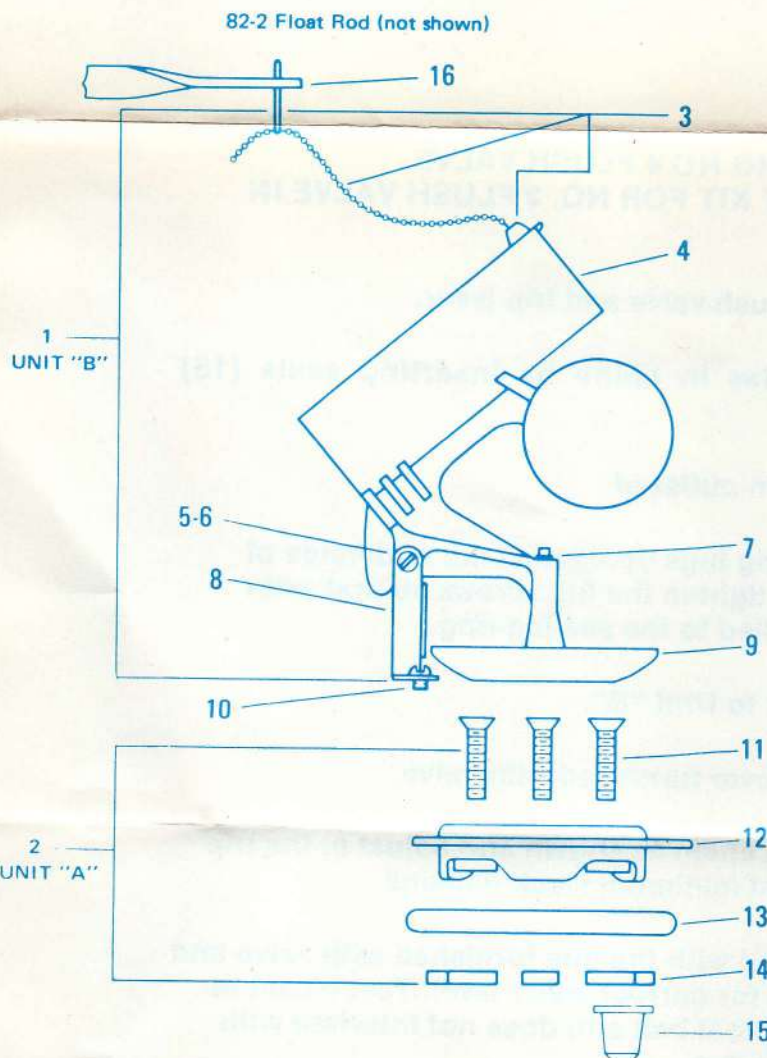

KEY No.	DESCRIPTION	PART No.	QTY
1	Unit "B"	8162	1
2	Unit "A"	—	1
3	Lift Chain S/A	8321	1
4	Actuating Unit	—	1
5	Screw	733-3	1
6	Nut	732-3	1
7	Screw	73382	1
8	Support Leg	722-2	1
9	Seat Disc	73383	1
10	Screw	737-2	2
11	Screw	729-2	3
12	Seat	—	1
13	Seal	—	1
14	Clamping Lug	—	3
15	Bolt Hole Seal	726-2	1
16	Lever	73439	1

IMPORTANT

THIS VALVE IS NOT A SUITABLE
REPLACEMENT IN ANY COMBINATION
IN WHICH OUTLET IS NOT IN CENTER OF TANK