

Water Connects Us®

G2/ECOS SINGLE FLUSH INSTALLATION INSTRUCTIONS FOR RETROFIT AND COMPLETE VALVE INSTALLATION



8100 Series Complete Flushometer Models

8100 Series G2/ECOS valves are complete flushometer valves and ideal for new installations.



RESS Series Retrofit Conversion Kit Models

RESS G2/ECOS models are used to convert existing Royal, Regal and Sloan style flushometers to sensor activation.

G2/ECOS Water Closet Models can be furnished for the following:

1.1 gpf/4.2 Lpf (ECOS combo unit only)	For High Efficiency Bowls
1.6 gpf/6.0 Lpf	For Low Consumption Bowls
2.4 gpf/9.0 Lpf	For 9 Liter European Water Closets
3.5 gpf/13.2 Lpf	For older Water Closets

G2/ECOS Urinal Models can be furnished for the following:

0.125 gpf/1.9 Lpf (ECOS only)	For High Efficiency Urinal
0.25 gpf/1.9 Lpf (ECOS only)	For High Efficiency Urinal
0.5 gpf/1.9 Lpf	For Wash Down Urinals
1.0 gpf/3.8 Lpf	For Low Consumption Urinals
1.5 gpf/5.7 Lpf	For older Siphon Jet Urinals
3.5 gpf/13.2 Lpf	For older Blow Out Urinals

Made in the U.S.A.



LIMITED WARRANTY

Unless otherwise noted, Sloan Valve Company warrants this product, manufactured and sold for commercial or industrial uses, to be free from defects in material and workmanship for a period of three (3) years (one (1) year for special finishes, SF faucets, PWT electronics and 30 days for PWT software) from the date of first purchase. During this period, Sloan Valve Company will, at its option, repair, replace, or refund the purchase price of any product which fails to conform with this warranty under normal use and service. This shall be the sole and exclusive remedy under this warranty. Products must be returned to Sloan Valve Company, at customer's cost. No claims will be allowed for labor, transportation or other costs. Damage caused by misuse or improper installation are all excluded from this warranty. This warranty extends only to person or organizations who purchase Sloan Valve Company's products directly from Sloan Valve Company for purpose of resale. This warranty does not cover the life of the batteries.

THERE ARE NO WARRANTIES WHICH EXTEND BEYOND THE DESCRIPTION ON THE FACE HEREOF. IN NO EVENT IS SLOAN VALVE COMPANY RESPONSIBLE FOR ANY CONSEQUENTIAL DAMAGES OF ANY MEASURE WHATSOEVER.

PRIOR TO INSTALLATION

Prior to installing the Optima Plus flushometer, install the items listed below as illustrated in the Rough-in Diagram. (New installations only.)

- Closet or Urinal fixture
- Drain line
- Water supply line

Important:

- **ALL PLUMBING SHOULD BE INSTALLED IN ACCORDANCE WITH APPLICABLE CODES AND REGULATIONS.**
- **WATER SUPPLY LINES MUST BE SIZED TO PROVIDE AN ADEQUATE VOLUME OF WATER FOR EACH FIXTURE.**

- **WHEN INSTALLING A FLUSHOMETER, IT IS IMPORTANT THAT THE FLUSH MODEL MATCHES THE REQUIREMENTS OF THE PLUMBING FIXTURE.**
- **FLUSH ALL WATER LINES PRIOR TO MAKING CONNECTIONS.**

The Optima Plus is designed to operate with 15 to 80 PSI (104 to 552 kPa) of water pressure. **THE MINIMUM PRESSURE REQUIRED TO THE VALVE IS DETERMINED BY THE TYPE OF FIXTURE SELECTED.** Consult fixture manufacturer for pressure requirements.

Most Low Consumption water closets (1.6 gallon/6 liter) require a minimum flowing pressure of 25 psi (172 kPa).

TOOLS REQUIRED FOR INSTALLATION

- Slotted screwdriver to adjust control stop.
- Sloan A-50 Super-Wrench™, Sloan A-109 Plier Wrench or smooth jawed spud wrench for couplings.
- Strap wrench (supplied) to install Optima Plus to valve body.
- 7/64" hex wrench (supplied) to secure Optima Plus cover to base plate.

VALVE ROUGH-IN

Typical Water Closet Installation

Model 8110/8111 Reference for RESS-C Retrofit

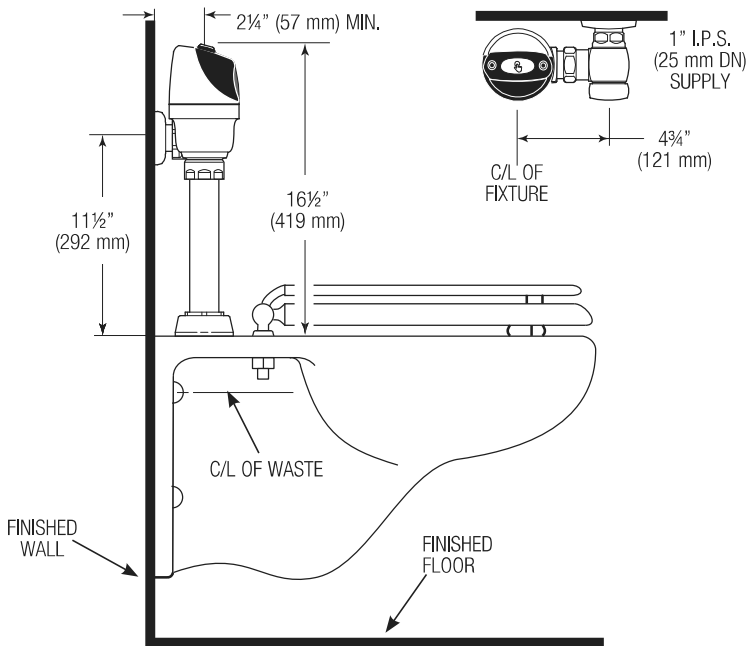

Typical Urinal Installation

Models 8180 & 8186 Reference for RESS-U Retrofit

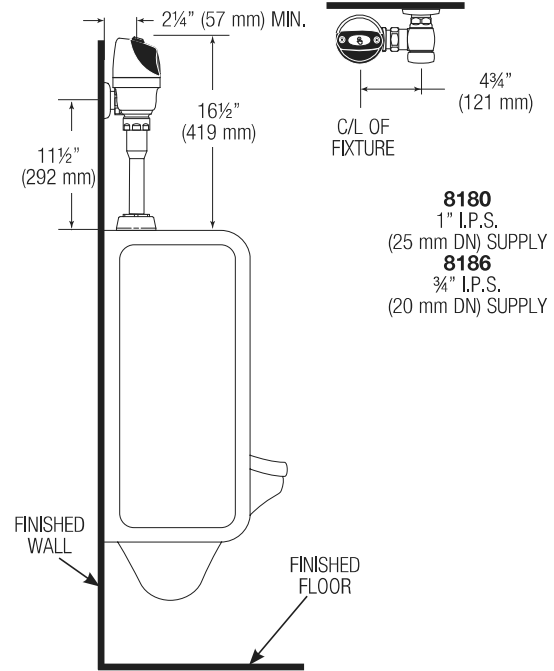

High Rough-in Water Closet Installation

Models 8113, 8115 & 8116

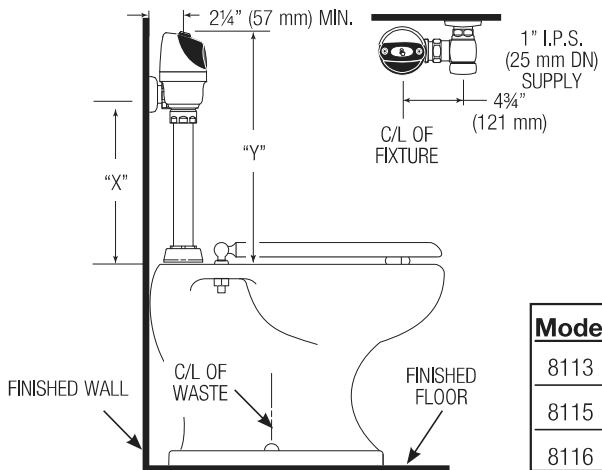

Model 8115 & 8116 valves are designed for installations where the water supply is roughed-in 24" - 27" (610 mm - 686 mm) above the top of the water closet.

For new installations, Sloan strongly recommends the use of our Model 8111 which has a shorter installation height.

Model	"X"	"Y"
8113	16" (406 mm)	21" (533 mm)
8115	24" (610 mm)	29" (737 mm)
8116	27" (686 mm)	32" (813 mm)

Squat Toilet Water Closet Installation Model 8137

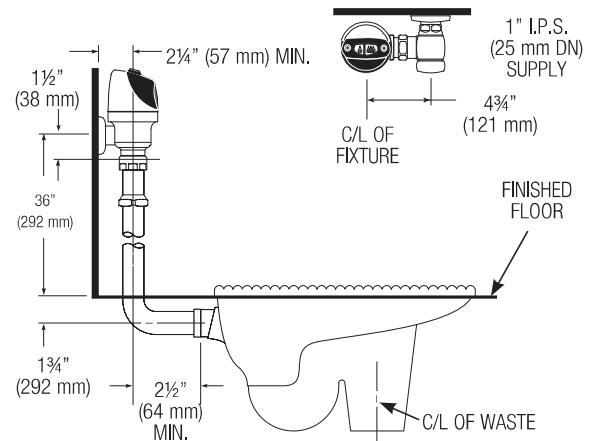

ALTERNATIVE WATER CLOSET INSTALLATION

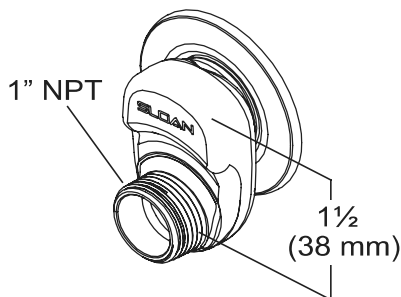

When installing the Sloan G2 Electronic Flushometer in an ADA compliant stall: Per ADA Guidelines (section 604.9.4) it is recommended that the grab bars be split or shifted to the wide side of the stall. For alternative installations, lower water supply rough-in to 10" (254 mm), or use the H-1018-A 1-1/2" offset adapter (not supplied) to lower the overall height. The Sloan H-1018-A 1" NPT x 1-1/2" offset adapter kit (sold separately) is designed to lower a G2 Flushometer 1-1/2" when the space above the top of the Flushometer conflicts with grab bar clearance. Mount the grab bar at the 36" (914 mm) maximum allowed height (top of grab bar at 36").

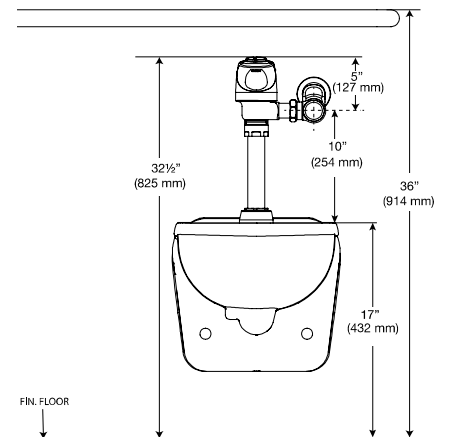

1 - FOR COMPLETE VALVE INSTALLATION START HERE. FOR RESS RETROFIT INSTALLATION, START AT STEP 6. INSTALL OPTIONAL SWEAT SOLDER ADAPTER (ONLY IF YOUR SUPPLY PIPE DOES NOT HAVE A MALE THREAD)

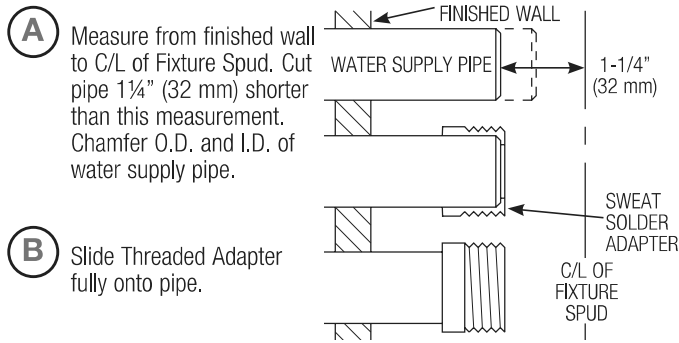

!!! IMPORTANT !!!

The Strap Wrench provided with Optima Plus is a convenience tool and is not to be used to remove or install the Flushometer Couplings. Use Strap Wrench ONLY to install Optima Plus Locking Ring.

When assistance is required, please contact Sloan Technical Support at:
1-888-SLOAN-14 (1-888-756-2614)
or visit us online at: sloan.com

C Sweat solder the Adapter to pipe.

!!! IMPORTANT !!!

With the exception of Control Stop Inlet, DO NOT use pipe sealant or plumbing grease on any valve component or coupling!

!!! IMPORTANT !!!

Protect the chrome or special finish of Sloan Flushometers — DO NOT USE toothed tools to install or service these valves. Use a Sloan A-50 Super-Wrench™, Sloan A-109 Plier Wrench or smooth jawed spud wrench to secure all couplings. Also see "Care and Cleaning" section of this manual.

!!! IMPORTANT !!!

LAWS AND REGULATIONS PROHIBIT THE USE OF HIGHER FLUSHING VOLUMES THAN LISTED ON FIXTURES OR FLUSHOMETERS.

!!! IMPORTANT !!!

This product contains mechanical and/or electrical components that are subject to normal wear. These components should be checked on a regular basis and replaced as needed to maintain the valve's performance.

2 - INSTALL COVER TUBE, WALL FLANGE AND CONTROL STOP TO SUPPLY PIPE

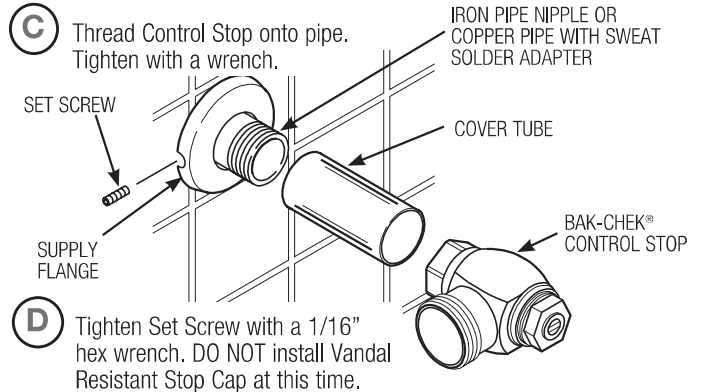
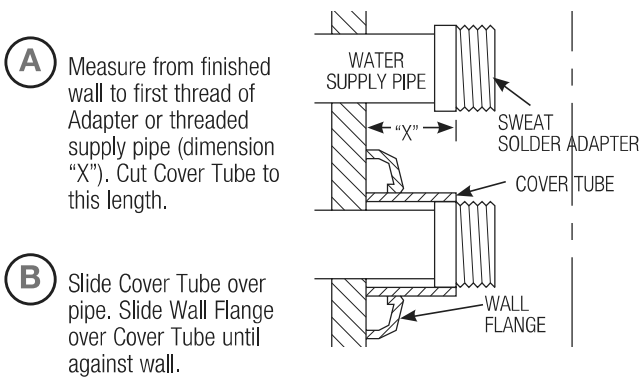

3 - FLUSH OUT SUPPLY LINE

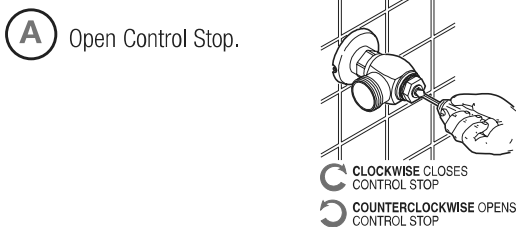

B Turn on water supply to flush line of any debris or sediment.

C Close Control Stop.

4 - INSTALL VACUUM BREAKER FLUSH CONNECTION

NOTE
If cutting Vacuum Breaker Tube to size, note that Critical Line (C/L) on Vacuum Breaker must typically be 6" (152 mm) above fixture. Consult Code for details.

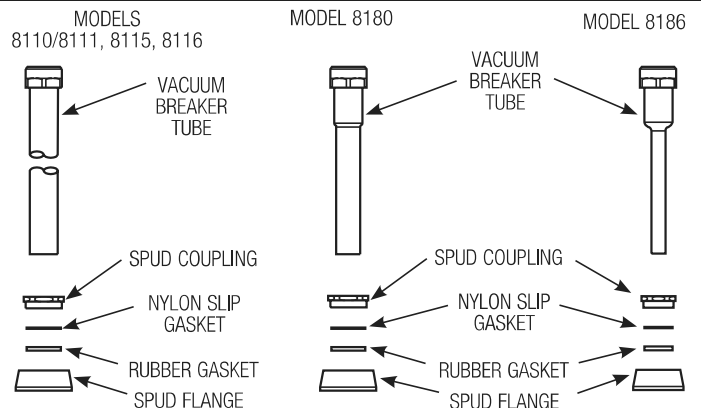
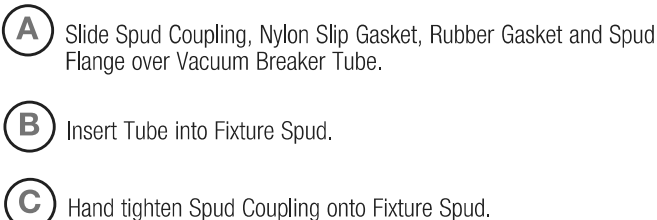

5 - INSTALL FLUSHOMETER

- A** Lubricate tailpiece O-ring with water. Insert Adjustable Tailpiece into Control Stop. Tighten Tailpiece Coupling by hand.

- B** Align Flushometer directly above the Vacuum Breaker Flush Connection by sliding the Flushometer Body IN or OUT as needed. Tighten Vacuum Breaker Coupling by hand.



NOTE

Maximum adjustment of the Sloan Adjustable Tailpiece is 1/2" (13 mm) IN or OUT from the standard 4-3/4" (121 mm) (centerline of Flushometer to centerline of Control Stop).

If roughing-in measurement exceeds 5-1/4" (133 mm), consult factory for longer tailpiece.

- C** Align Flushometer Body and securely tighten first the Tailpiece Coupling (1), then the Vacuum Breaker Coupling (2), and finally the Spud Coupling (3). Use a wrench to tighten these couplings in the order shown.

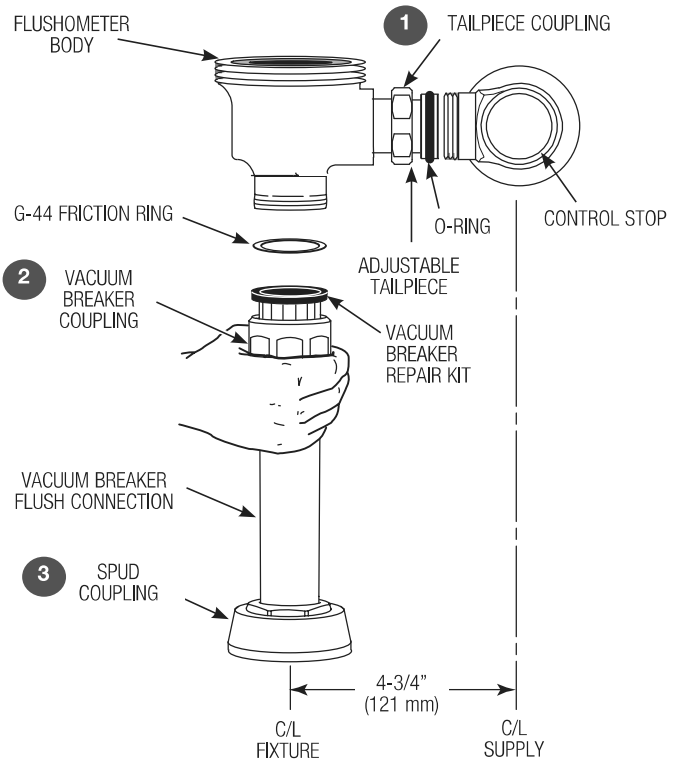

6 - WHEN RETROFITTING AN EXISTING VALVE, START HERE. REMOVE COMPONENTS FROM EXISTING FLUSHOMETER (RESS RETROFIT INSTALLATIONS ONLY)

- A** Remove Control Stop Cap.
- B** Turn off water supply at Control Stop. Push Valve Handle to relieve water pressure.
- C** Remove Outside and Inside Covers and old Inside Parts Kit.
- D** Remove old Handle Assembly and Gasket.
- E** Install Chrome Handle Cap with Gasket to handle opening on Flushometer Body. Tighten Chrome Handle Cap securely.

NOTE

An extra H-553 Tail O-ring is included in the event leakage occurs if the valve is repositioned during the installation of the new Optima Plus. USE ONLY AS NEEDED.

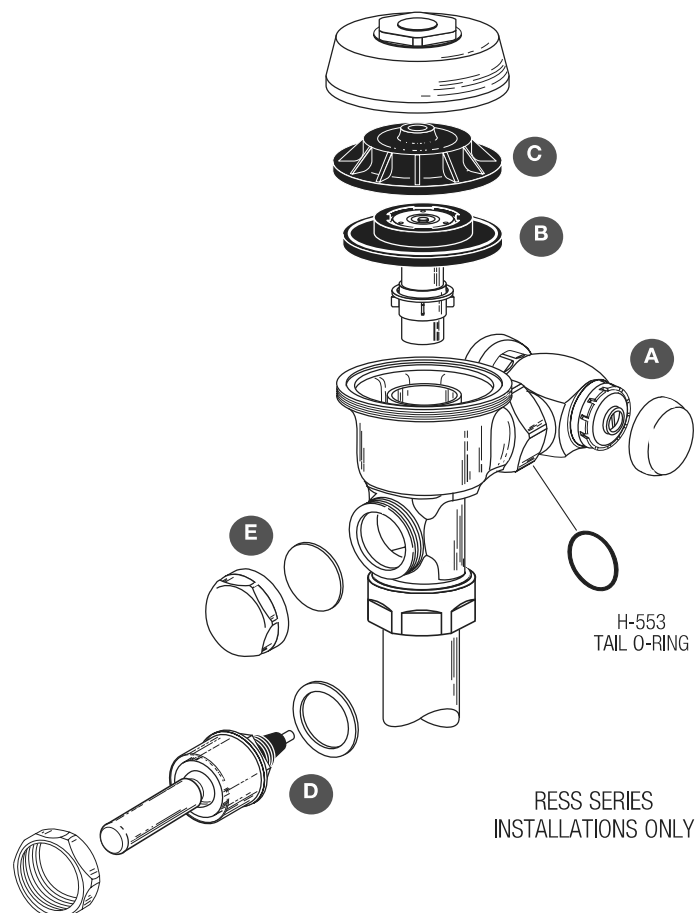

7 - G2/ECOS FLUSH VOLUME

The Flush Volume of the G2/ECOS is controlled by the Regulator in the Flex Tube Diaphragm Kit. Regulators are identified by color.

!!! IMPORTANT !!!
LAWS AND REGULATIONS PROHIBIT THE USE OF HIGHER FLUSHING VOLUMES THAN LISTED ON FIXTURES OR FLUSHOMETERS.

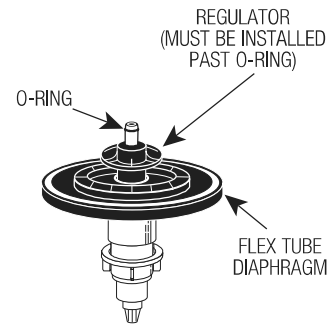

8 - ASSEMBLE FLEX TUBE DIAPHRAGM TO G2/ECOS ASSEMBLY

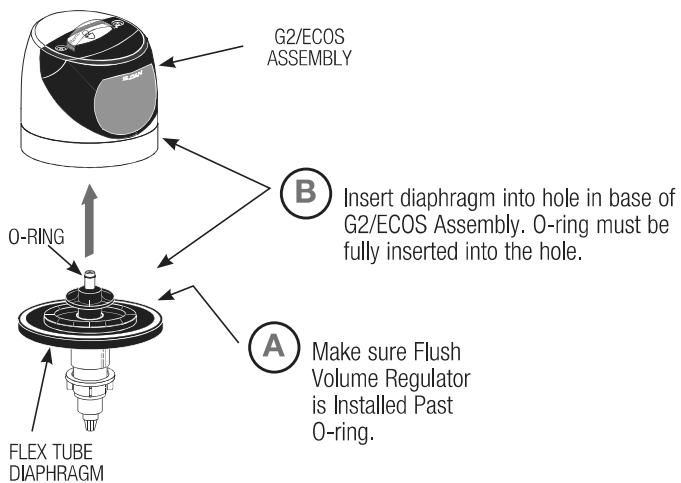

To facilitate installation, wet the diaphragm assembly (on top or completely).

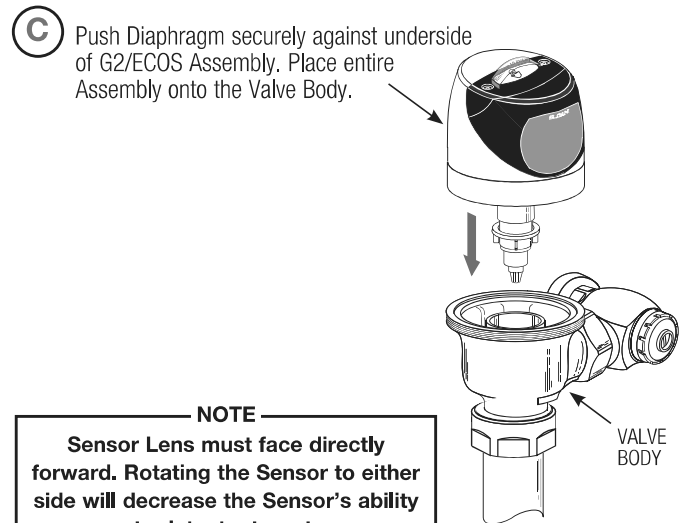

NOTE
Sensor Lens must face directly forward. Rotating the Sensor to either side will decrease the Sensor's ability to detect a target.

9 - TIGHTEN LOCKING RING

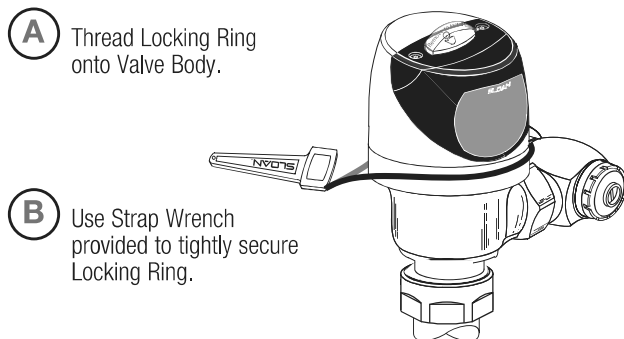

!!! IMPORTANT !!!
The Locking Ring must be installed down past the valve body threads by at least one thread. If difficulty is experienced installing the Locking Ring, turn the Locking Ring back and forth, each time working it further down the threads. The Locking Ring will act as a thread chaser in the event there has been a build-up of matter on the threads of the old valve body.

If retrofitting the Optima Plus onto a †Zurn valve body, a special Locking Ring must be used (identified by a machined groove around the ring).

Order the Optima Plus with the "Z" variation to receive the unit supplied with this Ring.

10 - REMOVE TAB TO ACTIVATE SENSOR MODULE

- A** Remove all removable objects in sensor view area and remove the Tab located over the Override Button to activate the Sensor Module. The sensor module will perform the start-up routine for one minute with LED blinking.
- B** After the start-up routine is complete, for the first ten (10) minutes of operation, a Visible LED Light flashes in the Sensing Window of the Optima Plus Flushometer when a user is detected.

NOTE
 The start-up routine will be 1 minute long and allows the sensors to adapt to the surrounding environment. It is VERY IMPORTANT that no non-permanent targets (i.e. persons, buckets, covers, etc) are present at this time. The start-up routine consists of a long (3 seconds) LED light ON, followed by slow LED light blinking in for 1 minute. At the end of the routine the sensor will show ONE long (2 seconds) LED light ON for lithium battery or TWO long (2 seconds each) LED light ON pulses for alkaline to complete the routine. Only at this time can the non-permanent objects be present.

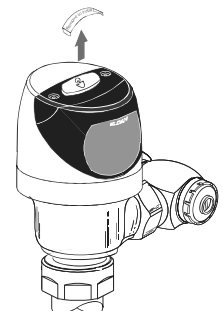

†Zurn® is a registered trademark of Zurco, Inc. Use of "Zurn" is for identification purposes only and does not imply affiliation, endorsement, or association between Sloan and Zurco, Inc.

11 - TEST SENSOR OPERATION

The G2/ECOS has a factory set sensing range:

Water Closet Models - 22" to 42" (559 mm to 1067 mm)

Urinal Models - 15" to 30" (381 mm to 762 mm)

The factory setting should be satisfactory for most installations. If a range adjustment is required, refer to the Range Adjustment instructions on this page.

- A** Test Sensor with Cover in Place.
- B** Step away from Sensor and listen for "CLICK."
- C** Step away from Sensor and listen for "CLICK."
*16 seconds-BT Water Closet Models
-

12 - ADJUST CONTROL STOP AND INSTALL VANDAL RESISTANT STOP CAP

- A** Open Control Stop COUNTERCLOCKWISE ½ turn from closed position.
- B** Activate Flushometer by placing hand in front of Optima Plus Sensor Lens for ten (10) seconds (or press override button) and then moving it away.
- C** Adjust Control Stop after each flush until the rate of flow delivered properly cleanses the fixture.
-

!!! IMPORTANT !!!

The flushometer is engineered for quiet operation. Excessive water flow creates noise, while too little water flow may not satisfy the needs of the fixture. Proper adjustment is made when plumbing fixture is cleaned after each flush without splashing water out from the lip AND a quiet flushing cycle is achieved.

!!! IMPORTANT !!!

The Control Stop should never be opened to the point where the flow from the valve exceeds the flow capability of the fixture. In the event of a valve failure, the fixture must be able to accommodate a continuous flow from the valve.

- D** Install Control Stop Cap onto Control Stop. For RESS retrofit applications, reuse Stop Cap from existing valve. In complete valve installations, a new Stop Cap is provided. For G2 models, follow the instructions packaged with the Free Spinning Vandal Resistant Stop Cap.

13 - OPERATION

1. A continuous, INVISIBLE light beam is emitted from the G2/ECOS Sensor.
2. After the user enters the beam's effective range for 8-16 seconds, (22 to 42 inches (559 mm to 1067 mm) for closet installations and 15 to 30 inches (381 mm to 762 mm) for urinal installations), the beam is reflected into the Scanner Window to activate the Output Circuit. Once activated, the Output Circuit continues in a "hold" mode for as long as the user remains within the effective range of the sensor.

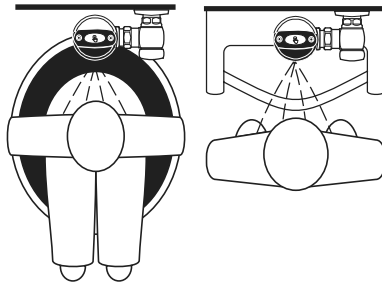

3. When the user steps away, the loss of reflected light initiates an electrical "one-time" signal that activates the flushing cycle to flush the fixture (1 second for urinal, 3 seconds for closet). The Circuit automatically resets and is ready for the next user.

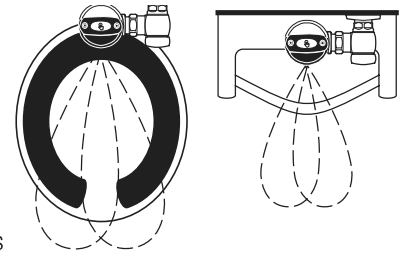

14 - RANGE ADJUSTMENT (ADJUST ONLY IF NECESSARY)

The G2/ECOS has a factory set sensing range:

Water Closet Models - 22" to 42" (559 mm to 1067 mm)

Urinal Models - 15" to 30" (381 mm to 762 mm)

The Factory setting should be satisfactory for most installations.

If the range is too short (i.e., not picking up users) or too long (i.e., picking up opposite wall or stall door) the range can be adjusted.

Note: Water does not have to be turned off to adjust range.

Make sure to remove all the non-permanent targets in sensor view area. Push manual override button for 20-30 seconds. the LED in the G2 sensor starts slow blinking. Release the button during the LED blinking. (For BT models, press manual override again for 20-30 seconds). The G2 will enter into distance setting mode. The setting mode will run for one minute.

NOTE: To automatically check battery strength, troubleshoot, diagnose and report issues with a wireless device, use the Sloan SmartPhone APP. The APP is available free-of-charge at the Apple iPhone APP store for iOS devices or the Google Play APP store for Android devices. For more information about the APP and its capabilities please visit Sloan.com.

To communicate with your flushometer, wave your hand 3 times in front of sensor within 10 seconds to activate your product or press and hold the override button for 12 seconds.

*-BT compatible models only

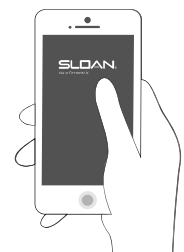

!!! IMPORTANT !!!

WHEN ADJUSTING RANGE FOR URINAL SENSOR, MAKE SURE TO SET-UP A PROPER TARGET IN FRONT OF URINAL SENSOR.

When further assistance is required, please contact Sloan Technical Support at:
+1.888.SLOAN.14 (+ 1.888.756.2614)
or visit us online at: sloan.com

15- BATTERY REPLACEMENT

When required, replace batteries with four (4) Alkaline AA-Size Batteries.

Note: Water does not have to be turned off to replace batteries

Loosen the two (2) Screws on top of unit. Remove the complete Cover Assembly. Lift the Sensor Module from its Plate. Unplug the Electrical Connector from Battery Compartment Cover. Loosen the Retaining Screw on Battery Compartment Cover and remove Battery Compartment Cover. Install four (4) Alkaline AA-Size Batteries exactly as illustrated. Install

Battery Compartment Cover and secure with Retaining Screw.

Note: Water only has to be turned off to replace batteries for Sloan Optima MC models

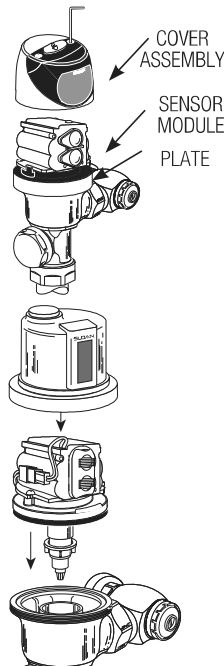

Make certain that Battery Compartment Cover is fully compressed against Gasket to provide a seal; Do Not over-tighten. Plug the Electrical Connector into the Battery Compartment Cover. Reinstall the Sensor Module onto the Plate. Reinstall the complete Cover Assembly onto the Plate. Tighten the two (2) Screws on top of the unit.

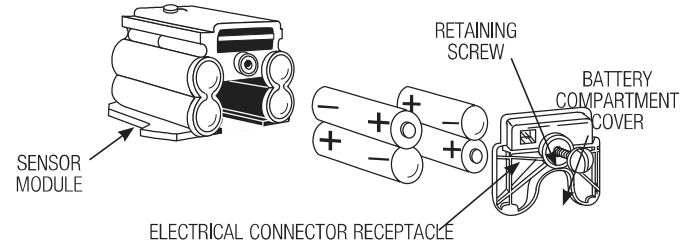

!!! IMPORTANT !!!

LAWS AND REGULATIONS PROHIBIT THE USE OF HIGHER FLUSHING VOLUMES THAN LISTED ON FIXTURES OR FLUSHOMETERS.

!!! NOTE !!!

THE EBV-46-A BEAM DEFLECTOR IS NO LONGER REQUIRED OR AVAILABLE FOR THE G2/ECOS.

16 - TROUBLESHOOTING (when servicing solenoid, rotating locking ring, servicing diaphragm, servicing vacuum breaker or spud, turn off water supply at control stop)

1. Sensor Flashes Continuously Only When User Steps Within Range.

- A. Unit in Start-Up mode; no problem. This feature is active for the first ten (10) minutes of operation.

2. Valve Does Not Flush; Sensor Not Picking Up User.

- A. Range too short; increase the range.

3. Valve Does Not Flush; Sensor Picking Up Opposite Wall or Surface, or Only Flushes When Someone Walks By. LED Light Flashes Continuously for First 10 Minutes Even with No One in Front of the Sensor.

- A. Range too long; shorten range.

4. Valve Does Not Flush Even After Adjustment.

- A. Improper Range Adjustment; Follow Instructions and repeat steps.
 B. Batteries completely used up; replace batteries.
 C. Problem with Electronic Sensor Module; replace Electronic Sensor Module.
 D. Try swapping module with working unit to test module function.
 E. Are there audible clicks from the solenoid?

NO, check for solenoid plugged into module; possibly solenoid stuck in closed position, replace solenoid.

YES, check solenoid for over-tightening, check to make sure locking ring was secured properly.

- F. If module is working and solenoid clicking, loosen and re-tighten locking ring; check diaphragm for perforations in diaphragm disk; replace.

5. LED Light Blinks 4 Times When User Steps Within Range.

- A. Batteries low; replace batteries.

6. Valve Does Not Shut Off.

- A. Bypass orifice in diaphragm is clogged with dirt or debris, or bypass is clogged by an invisible gelatinous film due to "over-treated" water. Remove flex tube diaphragm and wash under running water.

Note: Size of Orifice in the Bypass is of utmost importance for the proper metering of water by the valve. DO NOT ENLARGE OR DAMAGE THIS ORIFICE. Replace flex tube diaphragm if cleaning does not correct the problem.

- B. Dirt or debris fouling stem or flex tube diaphragm. Remove flex tube diaphragm and wash under running water.
 C. O-ring on stem of flex tube diaphragm is damaged or worn. Replace O-ring if necessary.
 D. Problem with Electronic Sensor Module; replace Sensor Module. Try swapping module with working unit to test module function.
 E. Are there audible clicks from the solenoid?

NO, possibly solenoid stuck in open position, replace solenoid

YES, check solenoid properly screwed into inside cover, check to make sure

locking ring was secured properly.

- F. If module is working and solenoid clicking, check diaphragm for perforations in diaphragm disc; replace.

7. Not Enough Water to Fixture.

- A. Wrong Flush Volume Regulator installed in Flex Tube Diaphragm Kit. Install the correct Regulator (see Section 7 of these instructions).
 B. Wrong G2/ECOS model installed; i.e., 1 gpf. urinal installed on 3.5 gal. closet fixture. Replace with proper G2/ECOS model, or refer to the G2/ECOS Conversion Guide to convert existing unit to the proper model.
 C. Enlarged Bypass in Diaphragm. Replace Flex Tube Diaphragm.
 D. Control Stop not adjusted properly. Readjust Control Stop.
 E. Inadequate volume or pressure at supply. Increase water pressure or supply (flow) to valve. Consult factory for assistance.

8. Too Much Water to Fixture.

- A. Wrong flush volume regulator installed in flex tube diaphragm kit. Install the correct regulator (see Step 7 of these instructions).
 B. Control Stop not adjusted properly. Readjust Control Stop.
 C. Wrong G2/ECOS model installed; i.e., 3 gpf. model installed on 1.0 or 1.5 gal. urinal fixture. Replace with proper G2/ECOS model, or refer to the G2/ECOS Conversion Guide to convert existing unit to the proper model.
 D. Dirt in diaphragm bypass. Clean under running water or replace flex tube diaphragm.

FCC INFORMATION TO USERS

This equipment has been tested and found to comply with the limits for a class B digital devices, pursuant to Part 15 of the FCC Rules. These limits are designed to provide reasonable protection against harmful interference in a residential installation. This equipment generates, uses, and can radiate radio frequency energy and, if not installed and used in accordance with the instruction manual, may cause harmful interference to radio or television reception, which can be determined by turning the equipment off and on, the user is encouraged to try to correct the interference by one or more of the following measures:

- Reorient or relocate the receiving antenna
- Increase the separation between the equipment and receiver
- Connect the equipment into an outlet on a circuit different from that to which the receiver is connected
- Consult the dealer or an experienced radio/TV technician for help

PARTS LIST

Item #	Part #	Description
--------	--------	-------------

Items Included with RESS Retrofit and Complete G2/ECOS Valves

1	EBV-138-A*	Cover/Ring/Sensor Assembly- Water Closet
	EBV-139-A*	Cover/Ring/Sensor Assembly- Urinal
	EBV-149-A	Cover/Ring/Sensor Assembly- Water Closet w/ †Zurn Ring
	EBV-150-A	Cover/Ring/Sensor Assembly- Urinal w/ †Zurn Ring
2A	EBV-142-A	Cover Assembly (G2/ECOS models)
2B	EBV-192-A	Cover Assembly (Sloan Optima Plus models)
2C	EBV-146A-C	Inner Cover/Sensor/Solenoid Assembly Water Closet (MC models only)
	EBV-146A-U	Inner Cover/Sensor/Solenoid Assembly Urinal (MC models only)
2D	EBV-60A	Metal Cover w/Override Button (includes EBV67 cover gasket)
3	EBV-130-A	Override Button Assembly (includes screws & hex wrench)
	EBV-132-A	Screws (2) and Hex Wrench Only
	EBV-182-A	Button Blank (not shown)
4	EBV-131	Lens Window Cover
5	EBV-14	Locking Ring
	EBV-30	Locking Ring - for †Zurn valves
6	EBV-129-A-C*	Electronic Module - Water Closet
	EBV-129-A-U*	Electronic Module - Urinal (G2 only)
	EBV-387-A*	Electronic Module - (0.5, 0.25 gpf ECOS) Urinal
	EBV-386-A*	Electronic Module - (0.125 gpf ECOS) Urinal
7	EBV-134	Cover Rest Plate
8	EBV-145-A	Inside Cover Assembly (includes solenoid)
9	EBV-136-A	Solenoid
10A	††	G2/ECOS Flex Tube Diaphragm Assembly
10B	††	Sloan Optima Plus Flex Tube Diaphragm Assembly
11	††	Flush Volume Regulator
12	EBV-1017-A	Handle Cap
13	EBV-22	Strap Wrench
14	EBV-137	7/64" Hex Wrench

Items Included with Complete Optima Plus Valves Only

15	H-633-AA	1" (25 mm) Sweat Solder Kit
	H-636-AA	¾" (19 mm) Sweat Solder Kit
16	H-700-A	1" (25 mm) Bak-Chek® Control Stop
	H-700-A	¾" (19 mm) Bak-Chek® Control Stop
17	H-1010-A	Vandal Resistant Stop Cap
18	EBV-36-A	Valve Body
18A	H-1015A	flow control for ONLY 0.5,0.25,0.125 gpf urinals
19A	V-600-AA	1½" (38 mm) Vacuum Breaker
19B	V-600-AA	1¼" (32 mm) Vacuum Breaker (Model 8180)
19C	V-600-AA	¾" (19 mm) Vacuum Breaker (Model 8186)
20A	F-5-AT	1½" Spud Coupling Assembly (Models 8110, 8111, 8115 & 8116)
20B	F-5-AU	1¼" Spud Coupling Assembly (Model 8180)
20C	F-5-AW	¾" Spud Coupling Assembly (Model 8186)

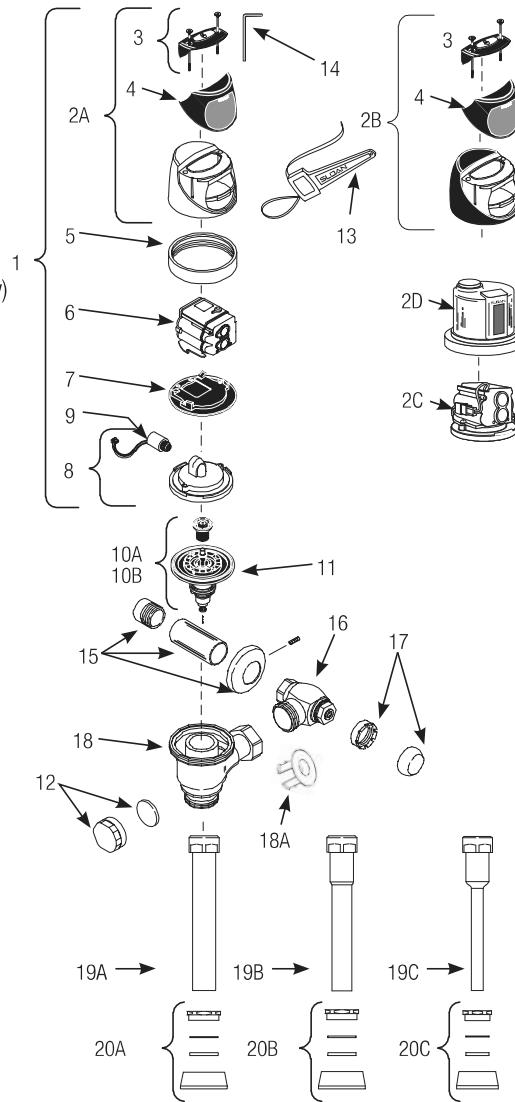

G2/ECOS Valve Models Feature Sloan's Exclusive Flex Tube Diaphragm for the ultimate in valve performance, reliability and chloramines resistance.

†Zurn® is a registered trademark of Zurco, Inc. Use of "Zurn" is for identification purposes only and does not imply affiliation, endorsement, or association between Sloan and Zurco, Inc.

*-BT Sloan Connected Product Models available

CARE AND CLEANING

DO NOT use abrasive or chemical cleaners to clean flushometers as they may dull the luster and attack the chrome or special decorative finishes. Use ONLY soap and water, then wipe dry with clean cloth or towel. While cleaning the bathroom tile, the Flushometer should be protected from any splattering of cleaner. Acids and cleaning fluids can discolor or remove chrome plating.

†† Part no. varies depending on valve model, please contact your local Sloan Representative or Sloan Technical Support at: 1-888-SLOAN-14 (1-888-756-2614)
The information contained in this document is subject to change without notice.

Manufactured in the U.S.A. by Sloan Valve Company under one or more of the following patents: U.S. Patents: D598,975; 7,124,997. Other Patents Pending. BAK-CHEK®, PARA-FLO®, PERMEX®, TURBO-FLO®.

SLOAN • 10500 SEYMOUR AVENUE • FRANKLIN PARK, IL 60131

Phone: +1.800.9.VALVE.9 or +1.800.982.5839 • Fax: +1.800.447.8329 or +1.847.671.4380 • sloan.com